



# Non-Contact RFID Coded Safety Switches

## MPZ MMZ Operating Instructions



MPZ (Plastic)



MMZ (S/Steel)

### READ AND UNDERSTAND THESE INSTRUCTIONS BEFORE INSTALLING, OPERATING, OR MAINTAINING THIS EQUIPMENT.

The product is designed to be a component of a customized safety oriented control system. It is the responsibility of each manufacturer to ensure the correct overall functionality of its systems and machines. IDEM, its subsidiaries and affiliates, are not in a position to guarantee all of the characteristics of a given system or product not designed by IDEM.

### APPLICATION:

RFID Coded Non-Contact Safety Switches are designed to interlock hinged, sliding or removable guard doors. They are specifically advantageous when:

- high level anti-tamper is required
- high hygiene requirements exist e.g. food industry hose down
- long mechanical life is required (no moving or touching parts)

MPZ / MMZ switches must be used in combination with a dual channel safety control device e.g. Safety Relay or Safety Controller.

MPZ / MMZ switches can be used to provide protection to PLe to ISO13849-1.

### OPERATION:

All switches are designed to conform to EN60947-5-3 and be used as directed by ISO14119 and EN ISO12100. They have coded RFID sensing which provides a wide (>10mm) sensing distance and provides a high tolerance to misalignment after sensing. They can operate in extreme environments of temperature and moisture.

The switches are provided factory coded either uniquely (U types – Type 4 High Coding to ISO14119) or anycode (A types – Type 4 Low Coding to ISO14119).

For U types the individual code numbers are shown on the reverse of switch / actuator. For A types any actuator will operate any switch.

### IMPORTANT:

Record any RFID codes as required by factory rules or with reference to any risk assessment for the particular application.

The Risk Assessment for the particular application should include the risk of spare actuators. Spare actuators should not be readily available and must be securely controlled.

The safety functions and mechanics must be tested regularly. For applications where infrequent guard access is foreseeable, the system must have a manual function test to detect a possible accumulation of faults. At least once per month for PLe or once per year for PLd (ISO13849-1). Where possible it is recommended that the control system of the machine demands and monitors these tests, and stops or prevents the machine from starting if the test is not done. (See ISO14119).

### INSTALLATION:

Installation of all Safety Switches must be in accordance with a risk assessment for the individual application.

The use of a Safety Relay or Safety Controller is required for monitoring MPZ / MMZ switches.

These devices monitor 2 redundant circuits as per ISO13849-1 for up to PLe protection.

Tightening torque for mounting bolts to ensure reliable fixing is 1.0 Nm.

Always mount on Non Ferrous materials.

After testing cover the mounting bolt holes with the cover caps provided (MPZ only).

The recommended setting gap is 3mm. The Safety Switch must not be used as a mechanical stop or be adjusted by striking with a hammer.

The actuator must not be allowed to strike the switch. Do not mount adjacent switches or actuators closer than 100mm.

Typical misalignment tolerance after setting is 5mm.

After installation always check each switch function by opening and closing each guard individually in turn and ensuring that the appropriate LEDs on the Safety Relay or Controller are illuminated when the switch is closed and are extinguished when the switch is open. Check that the machine stops and cannot be re-started when each switch is open.

### ACTUATOR OPERATING DIRECTIONS:

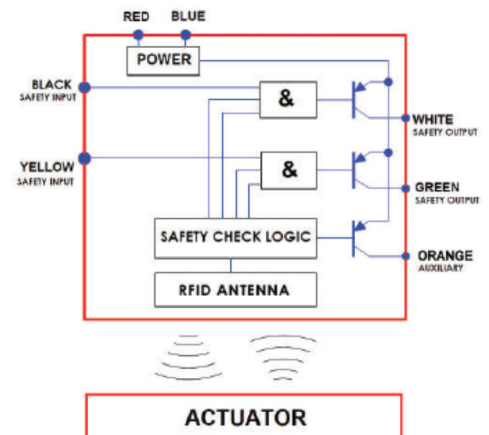

### MAINTENANCE:

Monthly: Check alignment of actuator and look for signs of mechanical damage to the switch casing.

Check wiring for signs of damage. Check each switch function by opening and closing each guard individually in turn and ensuring that the appropriate LED's on the Safety Relay or Controller are illuminated when the switch is closed and are extinguished when the switch is open. Check that the machine stops and cannot be re-started when each switch is open. Never repair any switch, actuator or integral cables. Replace any switch displaying signs of mechanical damage to the casing or cables.

**These requirements form part of the product warranty.**



### WARNING:

**DO NOT DEFEAT, TAMPER, OR BYPASS THE SAFETY FUNCTION. FAILURE TO DO SO CAN RESULT IN DEATH OR SERIOUS INJURY**

### AVERTISSEMENT:

**NE PAS DESACTIVER, MODIFIER, RETIRER, OU CONTOURNER CETI INTERVERROUILLAGE IL PEUT EN RESULTER DES BLESSURES GRAVES DU PERSONNEL UTILISATEUR.**

# Non-Contact RFID Coded Safety Switches

## Switch Dimensions (mm)

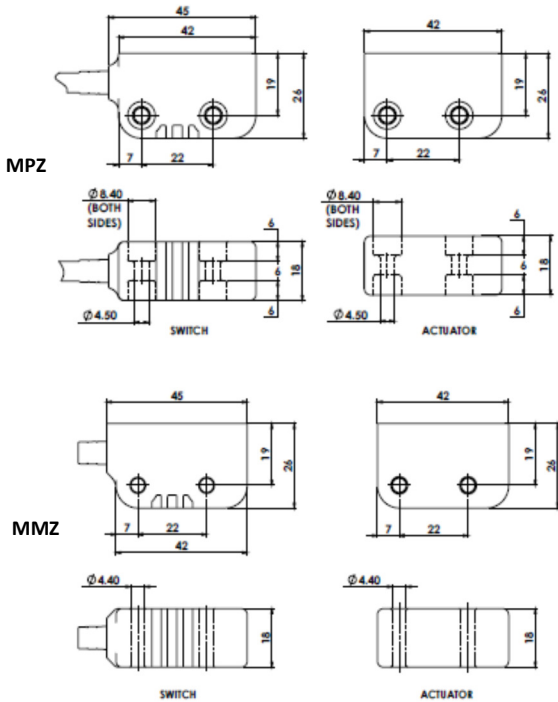

## LED Diagnostics

GUARD LED:	
Guard Closed	Green (Steady)
Code Incorrect	Red (Flash)
Guard Open	Red (Steady)

INPUT LED:	
Safety Inputs On	Green (Steady)
Safety Input Missing	Green (Flash)
Safety Inputs Off	Off
Internal Fault	Red (Steady)

OUTPUT LED:	
Safety Outputs On	Green (Steady)
Safety Outputs Missing	Green (Flash)
External Fault	Red (Flash)

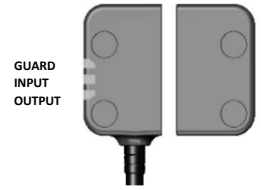

M12 QC 8-way Male Plug on 250mm Flying Lead (Pin view from switch)	Flying Lead Colours	Circuit	
	8	Orange	Auxiliary Signal Output (+24 Vdc)
	5	Brown	Not used
	4	Yellow	Safety Input 1
	6	Green	Safety Output 1
	7	Black	Safety Input 2
	1	White	Safety Output 2
	2	Red	Supply +24 Vdc
	3	Blue	Supply 0 Vdc

## Single switch to SCR-31P-i Safety Relay (Viper series):

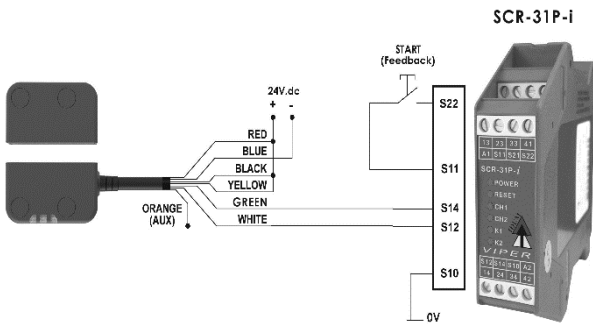

## Multiple switches to SCR-31P-i Safety Relay (Viper series):

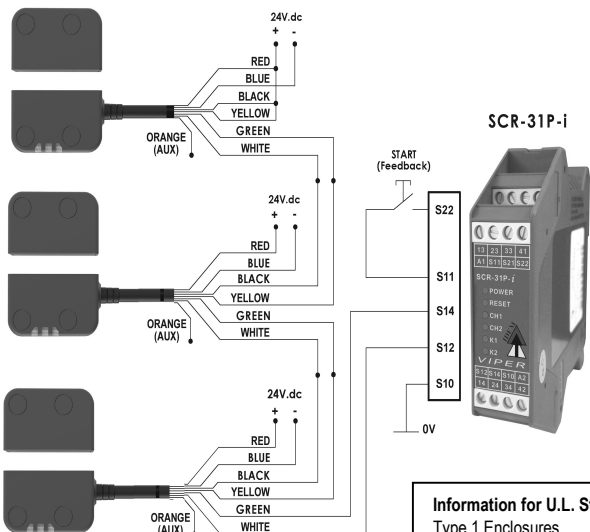

**Information for U.L. Standards:**  
 Type 1 Enclosures.  
 Maximum temperature 50°C.  
 Maximum output 24Vdc 100mA.  
 Powered by Class 2 or equivalent.

## Standards:

ISO14119 EN 60947-5-3 EN 60204-1 ISO 13849-1 EN 62061 UL508

## Technical Data:

Rated Operating Voltage	24 Vdc -15% +10%	Use SELV/PELV
Power Consumption	0.7W	
Outputs Rated Voltage	24 Vdc	
Outputs Max. Current	0.1 A	
Outputs Min. Current	1 mA	
Outputs Type	OSSD, PNP	
Inputs Rated Voltage	24 Vdc	
Inputs Rated Current	2 mA	
Auxiliary Signalling Output Rated Voltage	24 Vdc	
Auxiliary Signalling Output Max. Current	0.2 A	
Signalling Output Type	PNP	
Assured Switching Distances	SAO: 8mm SAR: 25mm	
Recommended Setting Gap	3mm	
Tolerance to Misalignment	+/-5mm in any direction from 5mm setting gap.	
Response Time Guard Open	60ms max.	
Response Time Inputs Off	20ms max.	
Operating Temperature	-25 / 55C	
Storage Temperature	-25 / 80C	
Dielectric Withstand	250V.ac	
Insulation Resistance	100 Mohms	
Enclosure Protection	IP67 IP69K (MMZ) wash-down	
Body material	MPZ Polyester MMZ Stainless Steel	

## Characteristic Data according to IEC62061 (used as a sub system)

Safety Integrity Level	SIL3	
PFH (1/h)	1.0 E-09	Corresponds to 1% of SIL3
PPF	8.8 E-05	Corresponds to 9% of SIL3
Proof Test Interval T <sub>1</sub>	20a	

## Characteristic Data according to EN ISO13849-1

Performance Level	e	
Category	4	
MTTF <sub>d</sub>	771a	
Diagnostic Coverage DC	High	

## Sales Part Numbers

417002	MPZ (A - anycode)	5m. cable	2 x OSSD + Aux.
417003	MPZ (A - anycode)	10m. cable	2 x OSSD + Aux.
417004	MPZ (A - anycode)	QC-M12 8 way Male on 250mm Flying Lead	2 x OSSD + Aux.
417201	MPZ Replacement Actuator (A - anycode)		
417102	MPZ (U - unique Code)	5m. cable	2 x OSSD + Aux.
417103	MPZ (U - unique Code)	10m. cable	2 x OSSD + Aux.
417104	MPZ (U - unique Code)	QC-M12 8 way Male on 250mm Flying Lead	2 x OSSD + Aux.
418002	MMZ (A - anycode)	5m. cable	2 x OSSD + Aux.
418003	MMZ (A - anycode)	10m. cable	2 x OSSD + Aux.
418004	MMZ (A - anycode)	QC-M12 8 way Male on 250mm Flying Lead	2 x OSSD + Aux.
418201	MMZ Replacement Actuator (A - anycode)		
418102	MMZ (U - unique Code)	5m. cable	2 x OSSD + Aux.
418103	MMZ (U - unique Code)	10m. cable	2 x OSSD + Aux.
418104	MMZ (U - unique Code)	QC-M12 8 way Male on 250mm Flying Lead	2 x OSSD + Aux.

ORIGINAL INSTRUCTIONS. To request this data sheet in other languages please contact [info@idemsafety.com](mailto:info@idemsafety.com)

# RFID Coded Non Contact with Auto Test Type: BPZ

## FEATURES & APPLICATION:

Will connect to most popular standard Safety Relays to maintain a PLe Safety Level even with switches connected in series.

M18 cylindrical barrel housing in high specification polyester, IP69K, can be used in almost any environment including high pressure cleaning.

Easy to understand LED diagnostic functions and provide auxiliary outputs for extra diagnostic signals to PLCs or computers.

The typical sensing distance "ON" is 10mm with wide tolerance to guard misalignment after setting.

RFID sensing provides a tamper resistant operation when the actuator is in the sensing range of the switch.

Available in 2 Versions:

**VERSION 1: Type M** Master code - any actuator will operate any switch. For when unique door activation is not required, but RFID makes it virtually impossible to be overridden or by-passed by simple means.

**VERSION 2: Type U** 32,000,000 Unique codes - factory set and used when **unique** activation is required in areas where there are many interlocked doors and security of individual areas is required.

IP69K



Quick Connect M12 versions fitted with 250mm (10") cable

## DIMENSIONS:

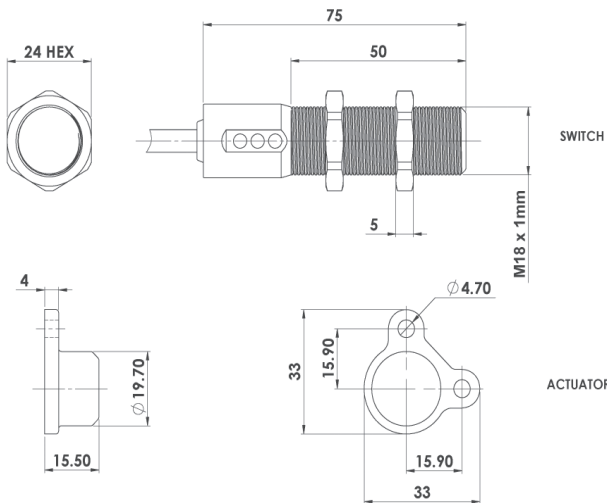

**Standards:** ISO14119 EN60947-5-3 EN62024-1  
ISO13849-1 EN62061 UL508

**Safety Classification and Reliability Data:**

- Minimum switched current: 10V.dc 1mA
- Dielectric Withstand: 250V.ac
- Insulation Resistance: 100 Mohms
- Recommended setting gap: 5mm
- Switching Distance: Sao 8mm Close Sar 20mm Open
- Tolerance to Misalignment: 5mm in any direction from 5mm setting gap
- Switching frequency: 1.0 Hz maximum
- Approach speed: 200mm/m to 1000mm/s
- Body material: Polyester M18 Barrel
- Temperature Range: -25/80C
- Enclosure Protection: IP67, IP69K
- Cable Type: PVC 6 or 8 core 6mm OD Conductors 0.25mm<sup>2</sup>
- Mounting Position: Any

**Characteristic Data according to IEC62061 (used as a sub system):**

- Safety Integrity Level SIL3
- PFH (1/h) 4.77E-10 Corresponds to 4.8% of SIL3
- Proof Test Interval T<sub>1</sub> 20a

**Characteristic Data according to EN ISO13849-1:**

- Performance Level e If both channels are used in combination with a SIL3/PLc control device
- Category Cat4
- MTTFd 1100a
- Diagnostic Coverage DC 99% (high)
- Number of operating days per year: d<sub>op</sub> = 365d
- Number of operating hours per day: h<sub>op</sub> = 24h
- B10d not mechanical parts implemented

When the product is used deviant from these assumptions (different load, operating frequency, etc.) the values have to be adjusted accordingly.

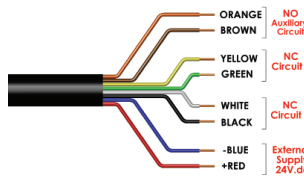
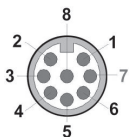

Quick Connect QC M12 8 Way Male Plug Pin view from Switch	Flying Lead Colour	Circuit (Actuator Present)
2	Red	Supply +24Vdc
3	Blue	Supply 0Vdc
7	Black	Safety Input 1
1	White	Safety Output 1
4	Yellow	Safety Input 2
6	Green	Safety Output 2
5		Not used
8	Orange	Auxiliary

SALES NUMBER	UNIQUELY CODED (every switch unique activation)	CABLE LENGTH
410101	BPZ-U	5M
410102	BPZ-U	10M
410103	BPZ-U	QC-M12

SALES NUMBER	MASTER CODED (same code every switch)	CABLE LENGTH
410001	BPZ-M	5M
410002	BPZ-M	10M
410003	BPZ-M	QC-M12
410200	Replacement Actuator Master Coded	

	140101	Female QC Lead	M12 Female 5m. 8 way
	140102	Female QC Lead	M12 Female 10m. 8 way

For all IDEM switches the normally closed (NC) circuits are closed when the guard is closed and the actuator is present.

# RFID Coded Non Contact with Auto Test Type: LPZ

## FEATURES & APPLICATION:

Will connect to most popular standard Safety Relays to maintain a PLE Safety Level even with switches connected in series.

High specification polyester housing, IP69K, can be used in almost any environment including high pressure cleaning with detergent.

Easy to understand LED diagnostic functions and provide auxiliary outputs for extra diagnostic signals to PLCs or computers.

The typical sensing distance "ON" is 12mm with wide tolerance to guard misalignment after setting.

RFID sensing provides a tamper resistant operation when the actuator is in the sensing range of the switch.

Available in 2 Versions:

**VERSION 1: Type M** Master code - any actuator will operate any switch. For when unique door activation is not required, but RFID makes it virtually impossible to be overridden or by-passed by simple means.

**VERSION 2: Type U** 32,000,000 Unique codes - factory set and used when **unique** activation is required in areas where there are many interlocked doors and security of individual areas is required.



Quick Connect M12 versions fitted with 250mm (10") cable

## DIMENSIONS:

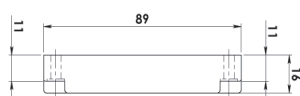
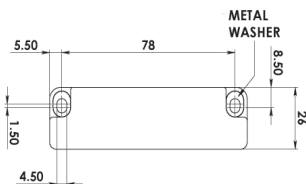
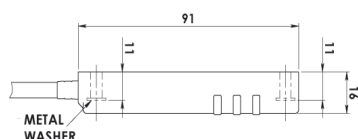
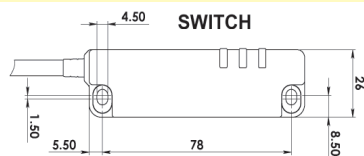

ACTUATOR

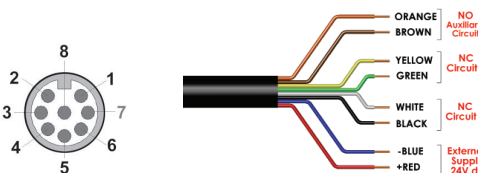

Quick Connect QC M12 8 Way Male Plug Pin view from Switch	Flying Lead Colour	Circuit (Actuator Present)
2	Red	Supply +24Vdc
3	Blue	Supply 0Vdc
7	Black	Safety Input 1
1	White	Safety Output 1
4	Yellow	Safety Input 2
6	Green	Safety Output 2
5		Not used
8	Orange	Auxiliary

For all IDEM switches the normally closed (NC) circuits are closed when the guard is closed and the actuator is present.

**Standards:** ISO14119 EN60947-5-3 EN60204-1  
ISO13849-1 EN62061 UL508

### Safety Classification and Reliability Data:

Minimum switched current:	10V.dc 1mA
Dielectric Withstand:	250V.ac
Insulation Resistance:	100 Mohms
Recommended setting gap:	5mm
Switching Distance:	Sao 10mm Close Sar 20mm Open
Tolerance to Misalignment:	5mm in any direction from 5mm setting gap
Switching frequency:	1.0 Hz maximum
Approach speed:	200mm/m to 1000mm/s
Body material:	Polyester
Temperature Range:	-25/80C
Enclosure Protection:	IP67, IP69K
Cable Type:	PVC 6 or 8 core 6mm OD Conductors 0.25mm <sup>2</sup>
Mounting Bolts:	2 x M4 Tightening torque 1.0 Nm
Mounting Position:	Any

### Characteristic Data according to IEC62061 (used as a sub system):

Safety Integrity Level	SIL3
PFH (1/h)	4.77E-10 Corresponds to 4.8% of SIL3
Proof Test Interval T <sub>1</sub>	20a

### Characteristic Data according to EN ISO13849-1:

Performance Level	e If both channels are used in combination with a SIL3/PLE control device
Category	Cat4
MTTFd	1100a
Diagnostic Coverage DC	99% (high)
Number of operating days per year:	d <sub>op</sub> = 365d
Number of operating hours per day:	h <sub>op</sub> = 24h
	B10d not mechanical parts implemented

When the product is used deviant from these assumptions (different load, operating frequency, etc.) the values have to be adjusted accordingly.

SALES NUMBER	UNIQUELY CODED (every switch unique activation)	CABLE LENGTH
402102	LPZ-U	5M
402103	LPZ-U	10M
402104	LPZ-U	QC-M12

SALES NUMBER	MASTER CODED (same code every switch)	CABLE LENGTH
402002	LPZ-M	5M
402003	LPZ-M	10M
402004	LPZ-M	QC-M12
402200	Replacement Actuator Master Coded	

140101	Female QC Lead	M12 Female 5m. 8 way
140102	Female QC Lead	M12 Female 10m. 8 way