

Heavy-Duty Beacons - 839

Your benefits

The heavy-duty beacons have the advantage of a robust and seawater-resistant aluminium housing unit in conjunction with a shock-resistant wire guard. These products are therefore especially suitable for use in harsh environments, locations exposed to seawater, or situations where excellent shock resistance is required.

- Maintenance-free operation permits use in locations where access is difficult
- Optimum protection against even severe mechanical strain or exposure to seawater

Typical applications

Signalling faults and relaying alarms

- In outdoor and indoor areas under extreme conditions
- For maritime applications on ships or in harbour areas

Installation options

- Base mounting
- Bracket mounting

Features

- Special screwed cable gland for equalising the pressure in the housing with the environmental pressure
- IP66 / 67 for use in harsh conditions



Size comparison EvoSIGNAL Midi/EvoSIGNAL Maxi/Heavy Duty



839 LED Rotating Beacon



① TECHNICAL SPECIFICATIONS/ORDER SPECIFICATIONS:

Dimensions (Ø x Height):	153 mm x 189 mm	
Housing:	Black coated aluminium with integral wire guard	
Lens:	PC, transparent	
Fixing:	Base mounting, Bracket mounting (accessory)	
Connection:	Screw terminal 0.5 -1.5 mm ²	
Cable entry:	Cable gland M20 x 1.5 mm (included in assembly) Cable diameter 6-13 mm	
Installation position:	As required	
Rotation rate:	c. 180 r.p.m.	
Life duration:	Up to 50,000 hrs	
Voltage:	24 V DC	115-230 V AC
Current consumption:	150 mA	70-180 mA
red	839 120 55	839 120 68
yellow	839 320 55	839 320 68

✂ ACCESSORIES:

Mounting bracket	975 839 02
------------------	-------------------

↔ TECHNICAL DIAGRAM:

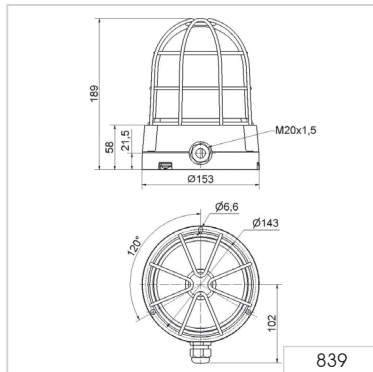

Mounting bracket
(accessory)

