

IS-DL105L Intrinsically Safe Alarm Sounder & LED beacon

Intrinsically Safe combination L.E.D beacon/light & alarm horn featuring marine grade aluminium enclosure, toughened glass lens and stainless steel guard.

The IS-DL105 unit is an intrinsically safe field mounting combined alarm horn with L.E.D. beacon/light which provides a a loud audible and bright flashing visual signal utilising a common zener barrier or galvanic isolator. The alarm horn features an alarm accept function – by closing a pair of external contacts (i.e push switch) the operator may silence the alarm for set periods between 5 seconds and 2 hours. If after the preset time the alarm condition still exists the sounder will activate again. Certified for use in application requiring Ex ia equipment to ATEX & IECEx the IS-DL105 is a globally accepted solution to fire or process control signalling.

Features

- Input overload and reverse current protection
- Prismatic lens optimises L.E.D effectiveness
- Marine grade aluminium enclosure
- Auto synchronised sound output
- External mounting lugs
- Duplicate cable terminations (in & out for daisy-chain installations).
- Available with custom tone configurations and frequencies.

Approvals

- ATEX certificate: SIRA 04ATEX2301X
- ATEX certificate: SIRA 04ATEX2302X
- IECEx certificate: IECEx SIR 04.0038X
- IECEx certificate: IECEx SIR 04.0039X



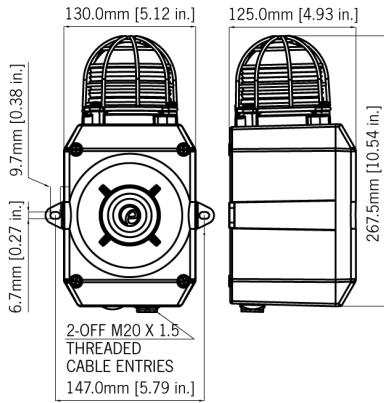

Specification

Sounder/horn:	
Nominal output:	105dB(A) @ 1m +/- 3dB - Tone 2* [96dB(A) @ 10ft/3m]
No. of tones:	49 (UK00A/PFEER compliant)
No. of stages:	3
Volume control:	Max. 105dB(A); Min. 96dB(A) - Tone 2
Effective range:	60m/197ft @ 1KHz
Beacon/light:	
Light source:	Array of 6 high intensity L.E.D's
L.E.D. colours:	Red, Amber, Blue & Green
Standalone mode:	2Hz (2 double flashes per second)
Flash rate:	On : 1 Hz (1 double flash per second) Silenced: 2 Hz (2 double flashes per second - alarm accepted)
General:	
Voltage:	16-28vdc via Zener barrier or galvanic isolator
Current:	25mA typical when powered from 24v supply via 28v 300 Ohm Zener barrier
Ingress protection:	IP66
Rating:	Continuous
Enclosure material:	A1-SI12 Marine Grade Aluminium
Housing colour:	RAL3000 Red or RAL7038 Grey
Fixings:	Stainless Steel
Cable entries:	2 x M20
Terminals:	0.5 to 2.5mm ²
Operating temp:	-40° to +60°C [-40° to +140°F]
Storage temp:	-40° to +70°C [-40° to +158°F]
Relative humidity:	90% at 20°C [68°F]
Weight:	2.10kg/4.62lbs

Part Codes

IS-DL105-[x]/[y]	
ATEX / IECEx II 1G Ex ia IIC T4 Ga (-40°C ≤ Ta ≤ +60°C)	
[x] : Enclosure colour:	R: Red G: Grey
[y] : LED colour:	R: Red A: Amber B: Blue G: Green
May be powered from any certified Zener barrier or galvanic isolator whose output parameters do not exceed: Uo : 28VDC Io : 93mA Po : 1.2W	

Tone table

S 1	Description	S 2	S 3	S 1	Description	S 2	S 3
T 1	340 Hz Continuous	T 2	T 5	T 33	745Hz @ 1Hz Intermittent	T 2	T 5
T 2	800/1000Hz @ 0.25 sec Alternating	T 17	T 5	T 34	1000 & 2000Hz @ 0.5 sec Alternating - Singapore	T 38	T 45
T 3	500/1200Hz @ 0.3Hz 0.5 sec Slow Whoop	T 2	T 5	T 35	420Hz @ 0.625 sec Australian Alert	T 36	T 5
T 4	800/1000Hz @ 1Hz Sweeping	T 6	T 5	T 36	500-1200Hz 3.75sec /0.25sec. Australian Evac.	T 35	T 5
T 5	2400Hz Continuous	T 3	T 20	T 37	1000Hz Continuous - PFEER Toxic Gas	T 9	T 45
T 6	2400/2900Hz @ 7Hz Sweeping	T 7	T 5	T 38	2000Hz Continuous	T 34	T 45
T 7	2400/2900Hz @ 1Hz Sweeping	T 10	T 5	T 39	800Hz 0.25sec on, 1 sec off Intermittent	T 23	T 17
T 8	500/1200/500Hz @ 0.3Hz Sweeping	T 2	T 5	T 40	544Hz (100mS)/440Hz (400mS) - NF S 32-001	T 31	T 27
T 9	1200/500Hz @ 1Hz - DIN / PFEER P.T.A.P.	T 15	T 2	T 41	Motor Siren - slow rise to 1200 Hz	T 2	T 5
T 10	2400/2900Hz @ 2Hz Alternating	T 7	T 5	T 42	Motor Siren - slow rise to 800 Hz	T 2	T 5
T 11	1000Hz @ 1Hz Intermittent	T 2	T 5	T 43	1200 Hz Continuous	T 2	T 5
T 12	800/1000Hz @ 0.875Hz Alternating	T 4	T 5	T 44	Motor Siren - slow rise to 2400 Hz	T 2	T 5
T 13	2400Hz @ 1Hz Intermittent	T 15	T 5	T 45	1KHz 1s on, 1s off Intermittent - PFEER Gen. ...	T 38	T 34
T 14	800Hz 0.25sec on, 1 sec off Intermittent	T 4	T 5	T 46	1200/500Hz @ 1Hz - DIN / PFEER P.T.A.P.	T 47	T 37
T 15	800Hz Continuous	T 2	T 5	T 47	1KHz 1s on, 1s off Intermittent - PFEER Gen. ...	T 46	T 37
T 16	660Hz 150mS on, 150mS off Intermittent	T 18	T 5	T 48	420Hz @ 0.625 sec Australian Alert	T 49	T 5
T 17	544Hz (100mS)/440Hz (400mS) - NF S 32-001	T 2	T 27	T 49	500-1200Hz 3.75sec /0.25sec. Australian Evac.	T 26	T 37
T 18	660Hz 1.8sec on, 1.8sec off Intermittent	T 2	T 5				
T 19	1.4KHz-1.6KHz 1s, 1.6KHz-1.4KHz 0.5s -NFC48-265	T 2	T 5				
T 20	660Hz Continuous	T 2	T 5				
T 21	554Hz/440Hz @ 1Hz Alternating	T 2	T 5				
T 22	544Hz @ 0.875 sec. Intermittent	T 2	T 5				
T 23	800Hz @ 2Hz Intermittent	T 6	T 5				
T 24	800/1000Hz @ 50Hz Sweeping	T 29	T 5				
T 25	2400/2900Hz @ 50Hz Sweeping	T 29	T 5				
T 26	Bell	T 2	T 15				
T 27	554Hz Continuous	T 26	T 5				
T 28	440Hz Continuous	T 2	T 5				
T 29	800/1000Hz @ 7Hz Sweeping	T 7	T 5				
T 30	300Hz Continuous	T 2	T 5				
T 31	660/1200Hz @ 1Hz Sweeping	T 26	T 5				
T 32	Two T chime.	T 26	T 15				

IS-AL105NL Intrinsically Safe Combined Signal

Intrinsically Safe combination L.E.D beacon/light & alarm horn.

The IS-A105N+IS-L101L unit is an intrinsically safe field mounting combined alarm horn with L.E.D. beacon/light which provides a a loud audible and bright flashing visual signal utilising a common Zener barrier or galvanic isolator. The alarm horn features an alarm accept function – by closing a pair of external contacts (i.e push switch) the operator may silence the alarm for set periods between 5 seconds and 2 hours. If after the pre-set time the alarm condition still exists the sounder will activate again. Certified for use in application requiring Ex ia or Class I Div 1 equipment the IS-A105N+IS-L101L is a globally accepted solution to fire or process control signalling.

Features

- Input overload and reverse current protection
- Prismatic lens optimises L.E.D effectiveness
- Auto synchronised sound output
- Unit can be mounted using external lugs or internal BESA compatible fixing positions.
- Duplicate cable terminations (in & out for daisy-chain installations).
- Available with custom tone configurations and frequencies.

Approvals

- ATEX certificate: SIR A 04ATEX2301X
- IECEx certificate: IECEx SIR 04.0038X
- FM approved:
- Ex EAC certificate: POCC GB.JB05.B03365

Coding

ATEX / IECEx / FM:

II 1G Ex ia IIC T4 Ga (-40°C ≤ Ta ≤ +60°C)

IS Class I, Zone 0, AEx ia IIC T4 Ta = +60°C

IS Class I, Division 1, Groups A, B, C, D T4

Ex EAC:

0ExialICT4 IP65 -40° to +60°C



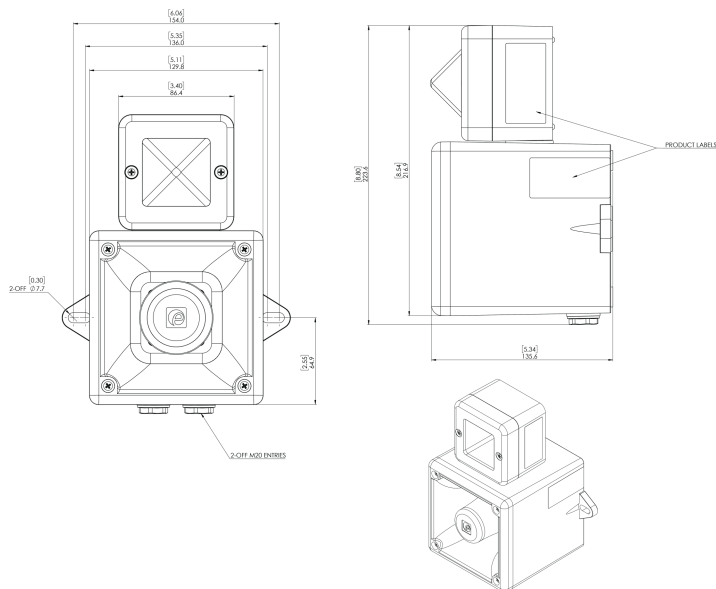

Specification

Sounder/horn:

Nominal output: 105dB(A) @ 1m +/- 3dB - Tone 2* [96dB(A) @ 10ft/3m]

No. of tones: 49 (UK00A/PFEER compliant)

No. of stages: 3

Volume control: Max. 105dB(A);
Min. 96dB(A) - Tone 2

Effective range: 60m/197ft @ 1KHz

Beacon/light:

Light source: Array of 6 high intensity L.E.D's

L.E.D. colours: Red, Amber, Blue, Green & White
Note: Blue, Green & White LED versions utilise a Clear lens

Standalone mode: 2Hz (2 double flashes per second)

Effective intensity 48cd* - measured ref. to I.E.S.
cd:

Flash rate: On: 1 Hz (1 double flash per second)
Silenced: 2 Hz (2 double flashes per second - alarm accepted)

General:

Voltage: 16-28vdc via Zener barrier or galvanic isolator

Current: 25mA typical when powered from 24v supply via 28v 300 Ohm Zener barrier

Ingress protection: IP66

Rating: Continuous

Enclosure material: UL94V0 & 5VA FR ABS

Enclosure colour: RAL 3000 Red, Grey RAL 7038

Fixings: Stainless Steel

Cable entries: 2 x M20 entries - stopping plugs included

Terminals: 0.5 to 2.5mm²

Operating temp: -40° to +60°C [-40° to +140°F]

Storage temp: -40° to +70°C [-40° to +158°F]

Relative humidity: 90% at 20°C [68°F]

Weight: 1.15kg/2.53lbs

*SPL data +/-3dB(A). Measured at optimum voltage.

Part Codes

ISAL 105NL-[x]/[y]

[x]: Enclosure colour:
Red RAL 3000
Grey RAL 7038

[y]: Lens/LED colour:
A: Amber
B: Blue
G: Green
R: Red
C: Clear (White LED)

Note: Note: Blue, Green & White LED versions utilise a Clear lens

May be powered from any certified Zener barrier or, galvanic isolator whose output parameters do not exceed:

Uo : 28VDC Io : 93mA Po : 1.2W

Tone table

S 1	Description	S 2	S 3	S 1	Description	S 2	S 3
T 1	340 Hz Continuous	T 2	T 5	T 33	745Hz @ 1Hz Intermittent	T 2	T 5
T 2	800/1000Hz @ 0.25 sec Alternating	T 17	T 5	T 34	1000 & 2000Hz @ 0.5 sec Alternating - Singapore	T 38	T 45
T 3	500/1200Hz @ 0.3Hz 0.5 sec Slow Whoop	T 2	T 5	T 35	420Hz @ 0.625 sec Australian Alert	T 36	T 5
T 4	800/1000Hz @ 1Hz Sweeping	T 6	T 5	T 36	500-1200Hz 3.75sec /0.25sec. Australian Evac.	T 35	T 5
T 5	2400Hz Continuous	T 3	T 20	T 37	1000Hz Continuous - PFEER Toxic Gas	T 9	T 45
T 6	2400/2900Hz @ 7Hz Sweeping	T 7	T 5	T 38	2000Hz Continuous	T 34	T 45
T 7	2400/2900Hz @ 1Hz Sweeping	T 10	T 5	T 39	800Hz 0.25sec on, 1 sec off Intermittent	T 23	T 17
T 8	500/1200/500Hz @ 0.3Hz Sweeping	T 2	T 5	T 40	544Hz (100mS)/440Hz (400mS) - NF S 32-001	T 31	T 27
T 9	1200/500Hz @ 1Hz - DIN / PFEER P.T.A.P.	T 15	T 2	T 41	Motor Siren - slow rise to 1200 Hz	T 2	T 5
T 10	2400/2900Hz @ 2Hz Alternating	T 7	T 5	T 42	Motor Siren - slow rise to 800 Hz	T 2	T 5
T 11	1000Hz @ 1Hz Intermittent	T 2	T 5	T 43	1200 Hz Continuous	T 2	T 5
T 12	800/1000Hz @ 0.875Hz Alternating	T 4	T 5	T 44	Motor Siren - slow rise to 2400 Hz	T 2	T 5
T 13	2400Hz @ 1Hz Intermittent	T 15	T 5	T 45	1KHz 1s on, 1s off Intermittent - PFEER Gen. ...	T 38	T 34
T 14	800Hz 0.25sec on, 1 sec off Intermittent	T 4	T 5	T 46	1200/500Hz @ 1Hz - DIN / PFEER P.T.A.P.	T 47	T 37
T 15	800Hz Continuous	T 2	T 5	T 47	1KHz 1s on, 1s off Intermittent - PFEER Gen. ...	T 46	T 37
T 16	660Hz 150mS on, 150mS off Intermittent	T 18	T 5	T 48	420Hz @ 0.625 sec Australian Alert	T 49	T 5
T 17	544Hz (100mS)/440Hz (400mS) - NF S 32-001	T 2	T 27	T 49	500-1200Hz 3.75sec /0.25sec. Australian Evac.	T 26	T 37
T 18	660Hz 1.8sec on, 1.8sec off Intermittent	T 2	T 5				
T 19	1.4KHz-1.6KHz 1s, 1.6KHz-1.4KHz 0.5s -NFC48-265	T 2	T 5				
T 20	660Hz Continuous	T 2	T 5				
T 21	554Hz/440Hz @ 1Hz Alternating	T 2	T 5				
T 22	544Hz @ 0.875 sec. Intermittent	T 2	T 5				
T 23	800Hz @ 2Hz Intermittent	T 6	T 5				
T 24	800/1000Hz @ 50Hz Sweeping	T 29	T 5				
T 25	2400/2900Hz @ 50Hz Sweeping	T 29	T 5				
T 26	Bell	T 2	T 15				
T 27	554Hz Continuous	T 26	T 5				
T 28	440Hz Continuous	T 2	T 5				
T 29	800/1000Hz @ 7Hz Sweeping	T 7	T 5				
T 30	300Hz Continuous	T 2	T 5				
T 31	660/1200Hz @ 1Hz Sweeping	T 26	T 5				
T 32	Two T chime.	T 26	T 15				