

Heavy Duty Combination – Multi-Tone Siren with Xenon Flash

Your benefits

The WERMA Heavy Duty Combination - Multi-Tone Siren with Xenon Flash features a very robust housing. The combination device provides safety and security through reliable, loud signalling in particularly harsh environments. Up to 120 dB for use in extremely noisy environments and signalling over long distances.

- Multiple visual and audible escalation levels possible
- Includes standardised tones
- Up to 42 tones for signalling various statuses

Typical applications

Signalling of faults

- Outdoors in extreme conditions
- In larger industrial plants

Installation options

- Wall mounting

Features

- High protection rating IP66
- Multi-voltage versions available



Size comparison Heavy Duty / Design



439 Xenon Flash / Multi-Tone Sounder Combination (105 dB)



① TECHNICAL SPECIFICATIONS/ORDER SPECIFICATIONS:

Dimensions (L x H x W):	136 mm x 138 mm x 119 mm	
Housing:	ABS	
Connection:	Screw terminal 0.28-2.5 mm ²	
Cable entry:	Cable gland M20 x 1.5 mm (not included in assembly)	
Flash frequency:	1 Hz	
Flash energy	1.6 Ws	
Tone type and frequency:	Selectable via DIP switch, 2 tones can be externally triggered	
Voltage:	9-60 V DC	110-230 V AC
Current consumption:	230 mA (24 V)	30 mA (230 V)
Housing/Flash		
red / red	439 010 55	439 010 68
red / yellow	439 030 55	439 030 68
grey / red	439 110 55	439 110 68
grey / yellow	439 130 55	439 130 68

✂ ACCESSORIES:

Cable gland M20 x 1.5 mm (for cable strain relief)	975 444 01
Protection rating IP 65 is guaranteed even without cable gland	

♪ TONE TYPES AND FREQUENCIES:

For further details see www.werma.com.

↔ TECHNICAL DIAGRAMS:

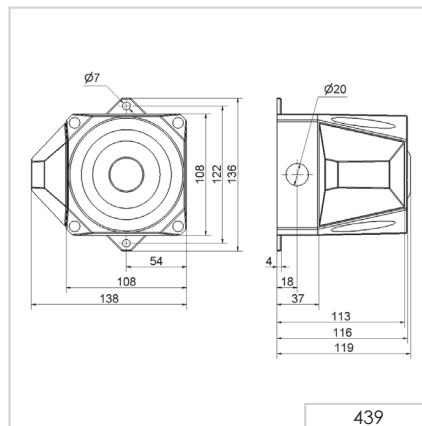

441 Xenon Flash / Multi-Tone Sounder Combination (110 dB)



① TECHNICAL SPECIFICATIONS/ORDER SPECIFICATIONS:

Dimensions (L x H x W):	165 mm x 169 mm x 132 mm	
Housing:	PC/ABS-Blend	
Connection:	Screw terminal 0.28-2.5 mm ²	
Cable entry:	Cable gland M20 x 1.5 mm (not included in assembly)	
Flash frequency:	1 Hz	
Flash energy	2.5 Ws	
Tone type and frequency:	Selectable via DIP switch, 2 tones can be externally triggered	
Voltage:	9-60 V DC	230 V AC
Current consumption:	230 mA	35 mA
Housing/Flash		
red / red	441 010 55	441 010 68
red / yellow	441 030 55	441 030 68
grey / red	441 110 55	441 110 68
grey / yellow	441 130 55	441 130 68

✂ ACCESSORIES:

Cable gland M20 x 1.5 mm (for cable strain relief)	975 444 01
Protection rating IP 65 is guaranteed even without cable gland	

🎵 TONE TYPES AND FREQUENCIES:

For further details see www.werma.com.

↔ TECHNICAL DIAGRAMS:

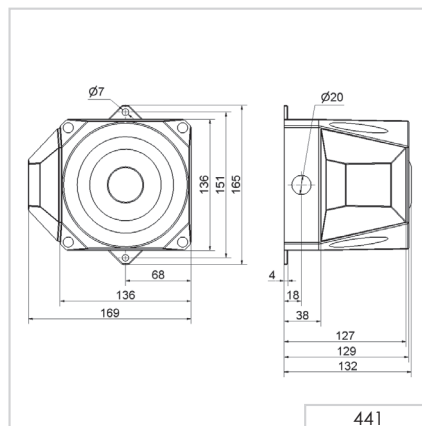

442 Xenon Flash / Multi-Tone Sounder Combination (120 dB)



① TECHNICAL SPECIFICATIONS/ORDER SPECIFICATIONS:

Dimensions (L x H x W):	168 mm x 211 mm x 155 mm	
Housing:	PC/ABS-Blend	
Connection:	Screw terminal 0.28-2.5 mm ²	
Cable entry:	Cable gland M20 x 1.5 mm (not included in assembly)	
Tone type and frequency:	Selectable via DIP switch, 3 tones externally triggered see table on page 221	
Voltage:	18-30 V DC	115/230 V AC
Current cons. Multi Tone Sounder:	450 mA	130/65 mA
Current consumption Flash:	127-389 mA (dependent on voltage and flash frequency)	- /15 mA (dependent on voltage and flash frequency)
Flash frequency	0.75 Hz/1 Hz	1.25 Hz/2 Hz
Flash energy	3.5 Ws	2 Ws
Housing/Flash		1 Hz (Flash can only be operated with 230 V)
red / red	442 010 55	442 010 68
red / yellow	442 030 55	442 030 68
grey / red	442 110 55	442 110 68
grey / yellow	442 130 55	442 130 68

✂ ACCESSORIES:

Cable gland M20 x 1.5 mm (for cable strain relief)	975 444 01
Protection rating IP 65 is guaranteed even without cable gland	

↔ TECHNICAL DIAGRAMS:

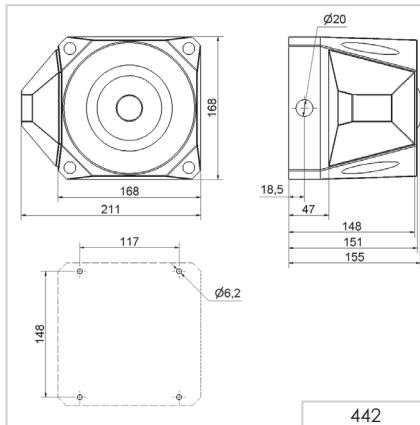

442 XX0 55 442 XX0 68

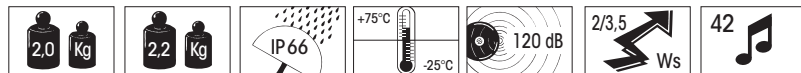

442 Combination

The Flash/Multi-Tone Sounder Combination 442 offers a large choice of internationally recognised signal tones for the widest spectrum of applications. 3 tones can be triggered externally. The first two tones can be freely chosen. The third tone is paired with the second tone.

♪ TONE TYPES AND FREQUENCIES:

Tone 1+2 No	Tone type	Use	Output (dbA)	Tone 3
1	alternating 800/970 Hz in 2 Hz stroke (250 ms-250 ms)		120	14
2	rising 800/970 Hz in 7 Hz stroke (7/s)		120	14
3	rising 800/970 Hz in 1 Hz stroke (1/s)		120	14
4	continuous 2,850 Hz		111	9
5	rising 2,400-2,850 Hz in 7 Hz stroke		109	4
6	rising 2,400-2,850 Hz in 1 Hz stroke		110	4
7	500-1,200 Hz rising in 3 sec., 0.5 sec. OFF	Slow Whoop Holland	119	14
8	falling 1,200-500 Hz in 1 Hz stroke	DIN/PFEER (PAPA), DIN 33404-3, VDS tested	119	14
9	alternating 2,400/2,850 Hz in 2 Hz stroke (250 ms-250 ms)		113	4
10	pulse 970 Hz in 0.5 Hz stroke (1 sec. ON / 1 sec. OFF)	PFEER Alarm	117	14
11	alternating 800/970 Hz in 1 Hz stroke (500 ms-500 ms)		118	14
12	pulse 2,850 Hz in 0.5 Hz stroke (1 sec. ON / 1 sec. OFF)		112	4
13	970 Hz pulse: 0.25 sec. ON / 1 sec. OFF		117	14
14	continuous 970 Hz	PFEER - Toxic gas	118	8
15	554 Hz/100 ms alternating 440 Hz/400 ms	French alarm signal AFNOR NFS 32S 32-001	115	14
16	660 Hz pulse: 150 ms ON, 150 ms. OFF	Swedish alarm signal	114	14
17	660 Hz pulse: 1.8 sec. ON, 1.8 sec. OFF	Swedish alarm signal	115	14
18	660 Hz pulse: 6.5 sec. ON, 13 sec. OFF	Swedish alarm signal	115	14
19	continuous 660 Hz	Swedish alarm signal	116	1
20	alternating 554/440 Hz in 0.5 Hz stroke (1 sec. ON / 1 sec. OFF)	Swedish alarm signal	115	19
21	pulse 660 Hz in 1 Hz stroke (500 ms-500 ms)	Swedish alarm signal	115	4
22	pulse 2,850 Hz in 4 Hz stroke (150 ms ON / 100 ms OFF)	Swedish alarm signal	110	4
23	rising 800-970 Hz in 50 Hz stroke	Swedish alarm signal	117	14
24	rising 2,400-2,850 Hz in 50 Hz stroke	Swedish alarm signal	110	4
25	970 Hz pulse.: 3 x 500 ms. ON, 500 ms OFF, break 1.5 sec.	ISO 8201 / US Temporal	118	14
26	2,850 Hz pulse.: 3 x 500 ms. ON, 500 ms OFF, break 1.5 sec.	ISO 8201 / US Temporal	112	4
27	continuous 4,000 Hz		105	6
28	alternating 800/970 Hz in 2 Hz stroke (250 ms-250 ms)		118	14
29	alternating 990/650 Hz in 2 Hz stroke (250 ms-250 ms)		117	14
30	alternating 510/610 Hz in 2 Hz stroke (250 ms-250 ms)		116	14
31	rising 300-1,200 Hz in 1 Hz stroke		118	14
32	continuous Bell		117	3
33	continuous Bell: 3x500 ms. Pulse, 1.5 sec. Silence, then repeat	Bell / US Temporal	117	14
34	alternating 1,000/2,000 Hz in 1 Hz stroke (500 ms-500 ms)	Singapore	115	4
35	pulse 420 Hz (0,625 sec.)	Australian alarm signal	118	14
36	500-1,200 Hz rising in 3.75 sec., then 0.25 sec. OFF	Australian alarm signal (Evacuation)	117	14
37	rising 1,400-1,600 Hz in 1 sec., falling in 0.5 sec.	NF C 48-265	116	14
38	500-1,200 Hz rising and falling in 3 sec.	Siren	117	14
39	pulse 720 Hz: 0.7 sec. ON, 0.3 sec. OFF	German industrial alarm	118	14
40	rising 422-775 Hz in 0.85 sec., 1 sec. silence, then repeat	NFPA Whoop	118	14
41	continuous 470 Hz	Horn (USA)	114	3
42	continuous 370 Hz	Air Horn (USA)	113	3

