



CLASSIC II FOOT SWITCH

The LINEMASTER® Classic II foot switch series is the second generation for the Classic family of pedals. The Classic II is a versatile foot switch that can be utilized in a wide range of applications and standard models include a guarded and unguarded options. The rugged cast aluminum housing offers an IP56 degree of protection. The guarded versions are designed with a heavy gauge steel full guard that covers the entire foot switch for added foot protection and also prevents faulty actuation. Contact Linemaster for a quotation on a custom variation built to your specifications.

LIT-056 Rev. B



LINEMASTER Switch Corporation
Tel (860) 974-1000

29 Plaine Hill Rd, P.O. Box 238
Woodstock, Connecticut 06281-0238 USA
Fax (800) 974-FOOT(3668)

www.linemaster.com

CLASSIC II FOOT SWITCH

FEATURES

- Cast aluminum body and treadle with steel base plate and nonskid base pad
- Single 3/4"-14 N.P.T. threaded conduit entry is standard
- All models single stage momentary contact
- EN 60529 Degree of Protection IP56
- Heavy Gauge Steel Full Guard available
- Two Holes Provided for Rigid Mounting to Floor Equipment
- Versatility of this model makes it ideal
- NEMA Type 1, 2, 4, & 13



GUARDED SINGLE MODEL

SIZE (HxWxD): 5.19 x 5.90 x 7.27 In.

WEIGHT: 2.75 lbs.









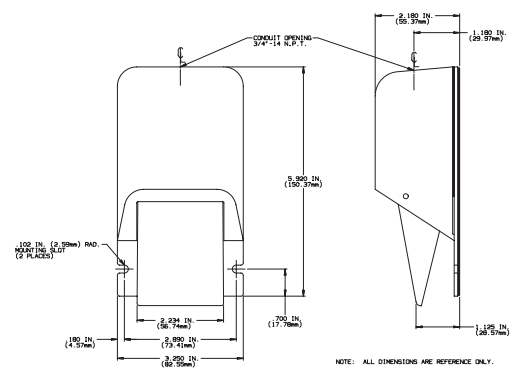
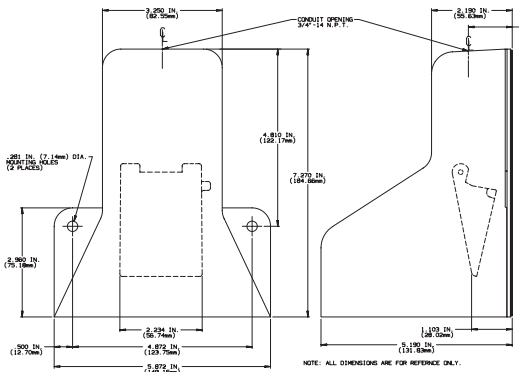

SINGLE MODEL

SIZE (HxWxD): 2.25 x 3.50 x 6.20 In.

WEIGHT: 1.50 lbs.



AGENCY APPROVALS	CATALOG NO.	DESCRIPTION	TYPE	CIRCUIT	FORM	ELECTRICAL RATING
 	78SN1	Momentary	UnGuarded	SPDT	C	20A 125-250 VAC 1 H.P. 125-250 VAC 250 VAC Maximum Heavy Pilot Duty
 	78SN2	Momentary	UnGuarded	DPDT	C	
 	78SH1	Momentary	UnGuarded	SPDT	C	
 	78SH2	Momentary	UnGuarded	DPDT	C	