

FlexSQUARE – Square shaped beacons

Your benefits

The compact 853 LED beacon is particularly versatile. With an IP67 protection rating, it is suitable for all indoor and outdoor applications, even in harsh environmental conditions.

- Powerful high-output, forward-directed light effect
- Clearly visible, also from the side
- Easy mounting and electrical installation thanks to the elastic, self-sealing, membranes or optional M20 cable gland for mounting on different sides
- Many combinations possible (traffic lights, for example)
- Where space is restricted: Multi-coloured version available, with up to seven colours

153 multi-tone siren:

- Loud audible signal to complement 853 beacon or as a stand-alone product
- Eight signal tones to choose from and a signal escalation option using three triggerable tones

Typical applications

Signalling of faults

- In lift and hoist systems (48 V)
- In building technology

Installation options

- Wall mounting
- Base mounting

Features

- Signal escalation possible with LED permanent light, LED double flash and EVS light in different colours
- Wide range of light effects and voltage options (12V, 24V, 48V and 115-230V)
- With the multi-coloured version, the three basic colours red, yellow and green can be activated with just two PLC outputs. With a third output, a further four colours are available

153 multi-tone siren:

- The sound output can be adjusted remotely



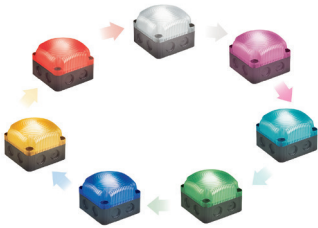
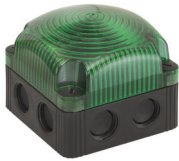

LED Permanent Light multicolour: 7 colours in one beacon: red, yellow, green, clear, blue, violet, turquoise

853 LED Permanent Beacon

① TECHNICAL SPECIFICATIONS/ORDER SPECIFICATIONS:

Dimensions (L x H x W):	85 mm x 85 mm x 72 mm
Housing:	PP-GF, black
Lens:	PC, transparent
Connection:	Screw terminal 0.5 - 1.5 mm ² CAGE CLAMP® 0.5 to 1.5 mm ² (Multicolour, RGY)
Fixing:	Wall, base and ceiling mounting
Possible colours:	Red, yellow, green, white, blue, violet, turquoise (multicolour)
Equipment:	Elastic self-sealing membranes for cable entry without tools Eight integrated M20 threads, no nuts required Optional use of a cable gland, thread length of cable gland ≤ 9 mm (accessory)
Assembly:	Incl. snap-on fixing bracket (optional use)
Life duration:	Up to 50,000 hrs

LED Permanent Beacon

Voltage:	12 V DC	24 V DC	48 V AC	115-230 V AC
Current consumption:	< 180 mA	< 80 mA	< 35 mA	< 40 mA
red	853 100 54	853 100 55	853 100 66	853 100 60
green	853 200 54	853 200 55	853 200 66	853 200 60
yellow	853 300 54	853 300 55	853 300 66	853 300 60
clear	853 400 54	853 400 55	853 400 66	853 400 60
blue	853 500 54	853 500 55	853 500 66	853 500 60

LED Permanent Beacon (multicolour)

Voltage:		24 V DC		115-230 V AC
Current consumption:		< 150 mA		< 35 mA
Multicolour		853 480 55		-
RGY (red, green, yellow)		-		853 480 60

✂ ACCESSORIES:

Connector for traffic light combinations	975 853 01
Cable gland M20 x 1.5 mm, 8mm thread length	975 853 02

← TECHNICAL DIAGRAM:

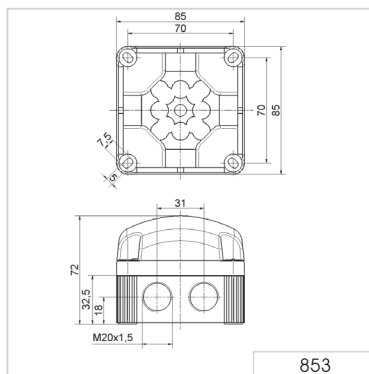

24 V

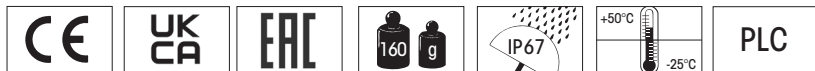

853 LED Double Flash Beacon

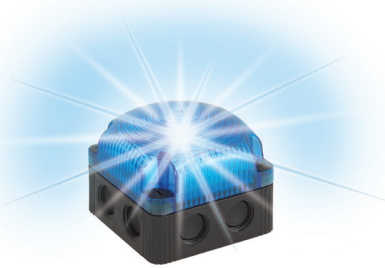

Intense double flash effect
with low power consumption

① TECHNICAL SPECIFICATIONS/ORDER SPECIFICATIONS:

Dimensions (L x H x W):	85 mm x 85 mm x 72 mm			
Housing:	PP-GF, black			
Lens:	PC, transparent			
Connection:	Screw terminal 0.5 - 1.5 mm ²			
Fixing:	Wall, base and ceiling mounting			
Equipment:	Elastic self-sealing membranes for cable entry without tools Eight integrated M20 threads, no nuts required Optional use of a cable gland, thread length of cable gland ≤ 9 mm (accessory)			
Assembly:	Incl. snap-on fixing bracket (optional use)			
Life duration:	Up to 50,000 hrs			
Voltage:	12 V DC	24 V DC	48 V AC	115-230 V AC
Current consumption:	< 100 mA	< 80 mA	< 95 mA	< 180 mA
red	853 110 54	853 110 55	853 110 66	853 110 60
green	853 210 54	853 210 55	853 210 66	853 210 60
yellow	853 310 54	853 310 55	853 310 66	853 310 60
clear	853 410 54	853 410 55	853 410 66	853 410 60
blue	853 510 54	853 510 55	853 510 66	853 510 60

✂ ACCESSORIES:

Connector for traffic light combinations	975 853 01
Cable gland M20 x 1.5 mm, 8mm thread length	975 853 02

↔ TECHNICAL DIAGRAM:

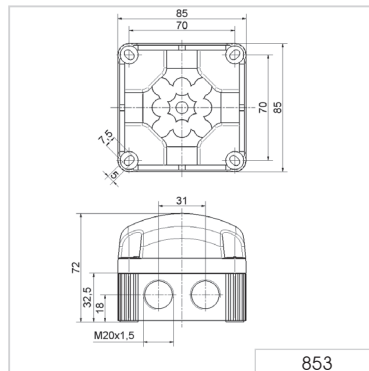



The innovative connector (accessory) enables traffic light combinations to be created in a matter of seconds

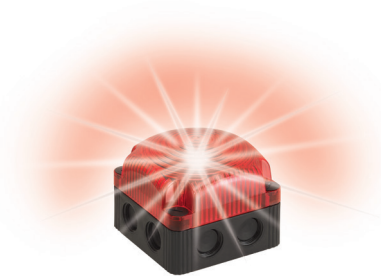

The "EVS" light signal ensures a maximum attention-grabbing effect

853 LED EVS Beacon

① TECHNICAL SPECIFICATIONS/ORDER SPECIFICATIONS:

Dimensions (L x H x W):	85 mm x 85 mm x 72 mm			
Housing:	PP-GF, black			
Lens:	PC, transparent			
Connection:	Screw terminal 0.5 - 1.5 mm ²			
Cable entry:	Cable diameter max. 8 mm, optional cable gland M20 (accessory)			
Fixing:	Wall, base and ceiling mounting			
Equipment:	Elastic self-sealing membranes for cable entry without tools Eight integrated M20 threads, no nuts required Optional use of a cable gland, thread length of cable gland ≤ 9 mm (accessory)			
Assembly:	Incl. snap-on fixing bracket (optional use)			
Life duration:	Up to 50,000 hrs			
Voltage:	12 V DC	24 V DC	48 V AC	115-230 V AC
Current consumption:	< 400 mA	< 200 mA	< 95 mA	< 160 mA
red	853 120 54	853 120 55	853 120 66	853 120 60
green	853 220 54	853 220 55	853 220 66	853 220 60
yellow	853 320 54	853 320 55	853 320 66	853 320 60
clear	853 420 54	853 420 55	853 420 66	853 420 60
blue	853 520 54	853 520 55	853 520 66	853 520 60

✂ ACCESSORIES:

Connector for traffic light combinations	975 853 01
Cable gland M20 x 1.5 mm, 8mm thread length	975 853 02

← TECHNICAL DIAGRAM:

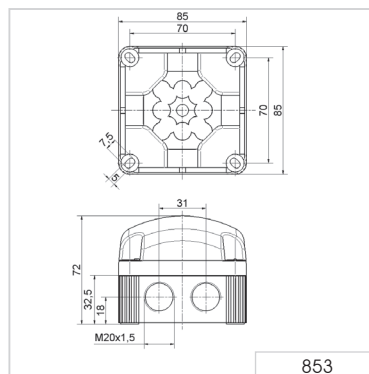

853 LED Traffic Light



The innovative connector (accessory) enables traffic light combinations to be created in a matter of seconds

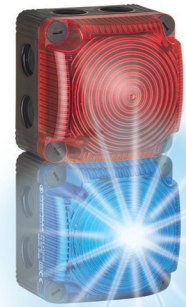

Three highly visible light effects are available



The LED beacon can be used with the sounder

TECHNICAL SPECIFICATIONS/ORDER SPECIFICATIONS:

Dimensions (L x H x W):	85 mm x 85 mm x 72 mm	
Housing:	PP-GF, black	
Lens:	PC, transparent	
Connection:	Screw terminal 0.5 - 1.5 mm ² CAGE CLAMP® 0.5 - 1.5 mm ² (Multicolour, RGY)	
Fixing:	Wall, base and ceiling mounting	
Possible colours:	Red, green, yellow, clear, blue	
Operating voltage:	12 V DC, 24 V DC, 115-230 V AC	
Current consumption:	Max. 80 mA at 24 V (LED Permanent Beacon) Max. 80 mA at 24 V (LED Double Flash Beacon) Max. 200 mA at 24 V (LED EVS Beacon) Max. 150 mA at 24 V (Multicolour)	
Equipment:	Eight self-sealing membranes for cable entry without tools Eight integrated M20 threads, no nuts required Optional use of a cable gland, thread length of cable gland ≤ 9 mm (accessory)	
Assembly:	Incl. snap-on fixing bracket (optional use)	
Life duration:	Up to 50,000 hrs	
LED Permanent Beacon 853		see page 134
LED Permanent Beacon 853 (multicolour)		see page 134
LED Permanent Beacon 853 (RGY)		see page 134
LED Double Flash Beacon 853		see page 135
LED EVS Beacon 853		see page 136
Sounder 153		see next page

ACCESSORIES:

Connector for traffic light combinations	975 853 01
Cable gland M20 x 1.5 mm, 8mm thread length	975 853 02

TECHNICAL DIAGRAM:

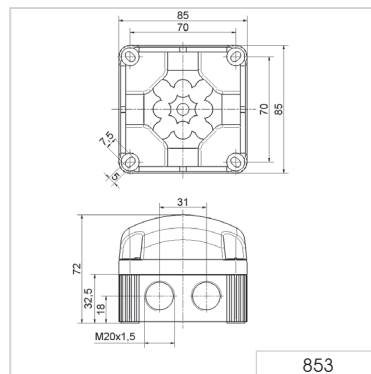

CE	UK CA	EAC	853 X00 XX 135 g	853 X10 XX 130 g	853 X20 XX 130 g	IP67	+50°C -25°C	24 V PLC
----	-------	-----	---------------------	---------------------	---------------------	------	----------------	-------------





The innovative connector (accessory) enables traffic light combinations to be created in a matter of seconds

853/153 Sounder/ LED Beacon Combination

TECHNICAL SPECIFICATIONS/ORDER SPECIFICATIONS:

Dimensions (L x H x W):	85 mm x 85 mm x 72 mm			
Housing:	PP-GF, black			
Lens:	LED Beacon 853: PC, transparent Sounder 153: PC, tinted black			
Connection:	Screw terminal 0.5 - 1.5 mm ²			
Cable entry:	Cable diameter max. 8 mm, optional Cable gland M20 (accessory)			
Fixing:	Wall and ceiling mounting			
Current consumption:	Max. 200 mA at 24 V			
Equipment:	Eight self-sealing membranes for cable entry without tools Eight integrated M20 threads, no nuts required Optional use of a cable gland, thread length of cable gland ≤ 9 mm (accessory)			
Assembly:	Incl. snap-on fixing bracket (optional use)			
Voltage:	12 V DC	24 V DC	48 V AC	115-230 V AC
Current consumption:	70 mA	120 mA	150 mA	75 mA (115 V) 150 mA (230 V)
Order no.:	153 000 54	153 000 55	153 000 66	153 000 60

The technical specifications and order specifications of the LED Beacons can be found at www.werma.com or on page 134 (LED Permanent Beacon), page 135 (LED Double Flash Beacon) and page 136 (LED EVS Beacon).

ACCESSORIES:

Connector for traffic light combinations	975 853 01
Cable gland M20 x 1.5 mm, 8mm thread length	975 853 02

TONE TYPES AND FREQUENCIES:

Tone	Tone type	Tone	Tone type
1	Continuous tone (c. 3000 Hz)	5	800 - 970 Hz rising @ 1 H
2	Horn tone (c. 110 Hz)	6	2400 - 2850 Hz rising @ 7 Hz
3	1 Hz tone (c. 3,0 kHz)	7	1200 - 500 Hz falling @ 1 Hz
4	20 Hz whistle tone (c. 3,0 kHz)	8	Alternating tone 800 Hz/1200 Hz@1 Hz

TECHNICAL DIAGRAM:

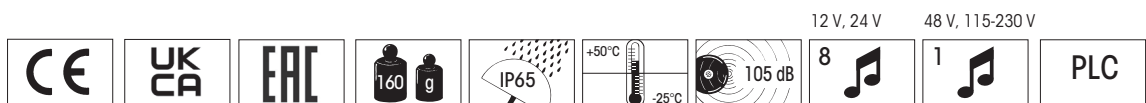
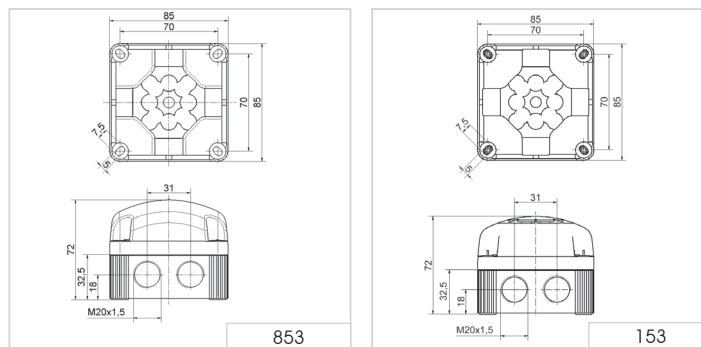

12 V, 24 V 48 V, 115-230 V